

# Heater type: TH - 03

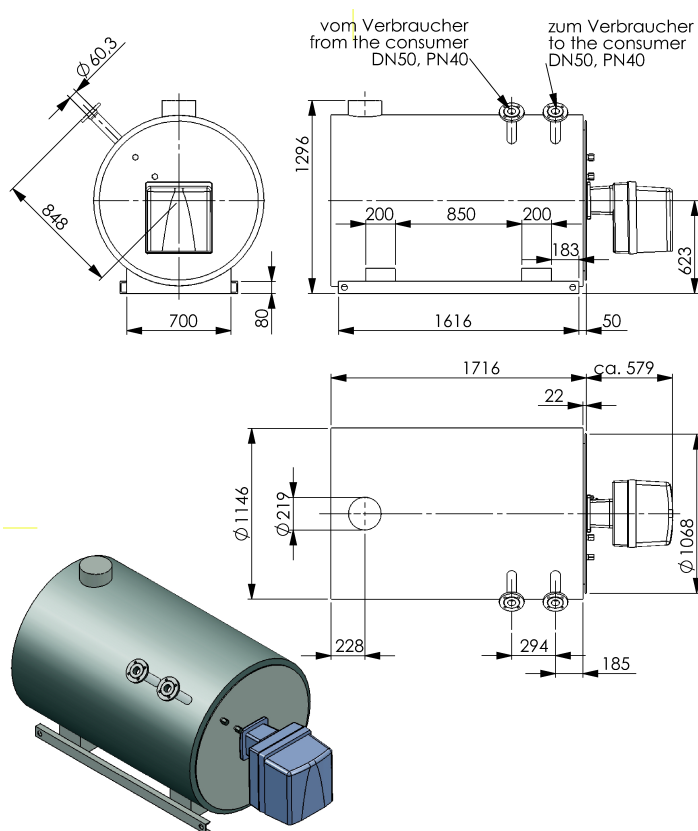

Nominal capacity	300kW
Thermal fluid content	167 l
Weight without filling	980 kg
Nominal thermal fluid volume flow	21 m <sup>3</sup> /h
Thermal fluid pressure drop	26 m flc.
Design temperature	300 °C
Temperature difference outlet - inlet	25 K
Heating surface	14,0 m <sup>2</sup>
Insulation thickness	120 mm
Recommended pump size @ 15mflc remaining height to provide consumers	32-200
Recommended motor power	5,5 kW

	LFO firing	Natural Gas firing
Thermal efficiency:	86,83 %	86,00 %
Fuel consumption:	29,13 kg/h	34,88 Nm <sup>3</sup> /h
Furnace pressure drop:	491 Pa	516 Pa
Combustion air consumption:	389 Nm <sup>3</sup> /h	375 Nm <sup>3</sup> /h
Exhaust gas outlet volume flow:	412 Nm <sup>3</sup> /h	414 Nm <sup>3</sup> /h
Exhaust gas outlet temperature:	303 °C	306 °C
Specific furnace load:	960 kW/m <sup>3</sup>	969 kW/m <sup>3</sup>