

Heater type: TH - 18

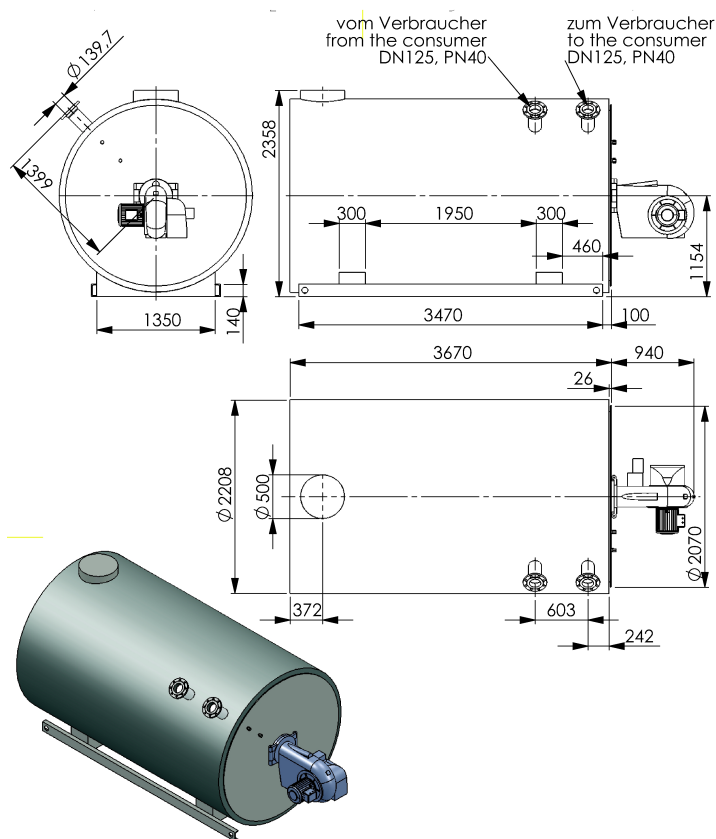

Nominal capacity	1800 kW
Thermal fluid content	2175 l
Weight without filling	6065 kg
Nominal thermal fluid volume flow	129 m <sup>3</sup> /h
Thermal fluid pressure drop	25 m flc.
Design temperature	300 °C
Temperature difference outlet - inlet	25 K
Heating surface	75,21 m <sup>2</sup>
Insulation thickness	150 mm
Recommended pump size @ 15mflc remaining height to provide consumers	65-200
Recommended motor power	22 kW

	LFO firing	Natural Gas firing
Thermal efficiency:	86,20 %	85,27 %
Fuel consumption:	176,06 kg/h	211,09 Nm <sup>3</sup> /h
Furnace pressure drop:	860 Pa	913 Pa
Combustion air consumption:	2348 Nm <sup>3</sup> /h	2273 Nm <sup>3</sup> /h
Exhaust gas outlet volume flow:	2492 Nm <sup>3</sup> /h	2505 Nm <sup>3</sup> /h
Exhaust gas outlet temperature:	317 °C	321 °C
Specific furnace load:	550 kW/m <sup>3</sup>	555 kW/m <sup>3</sup>