

Heater type: TH - 20

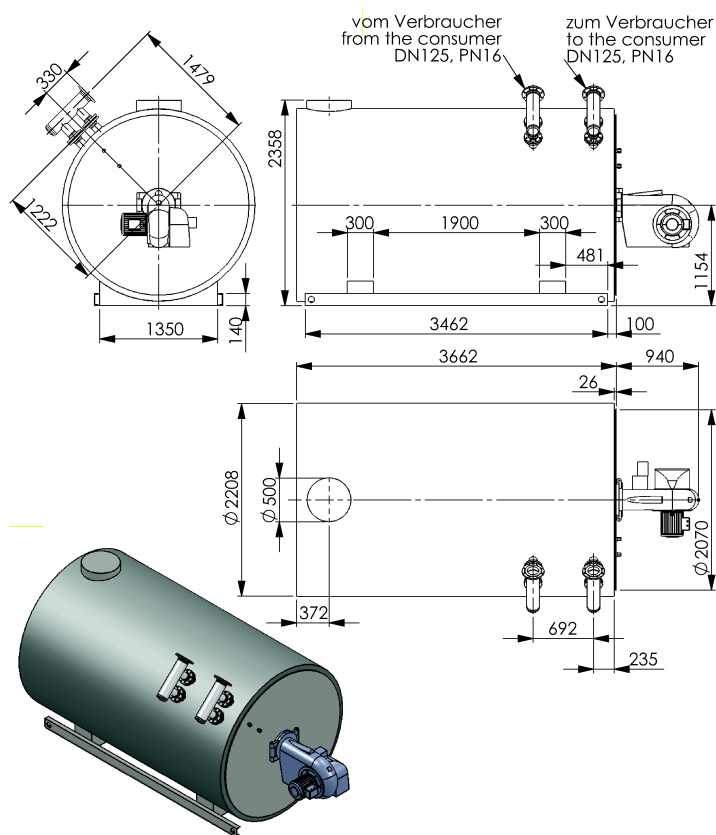

Nominal capacity	2000 kW
Thermal fluid content	1566 l
Weight without filling	5550 kg
Nominal thermal fluid volume flow	141 m ³ /h
Thermal fluid pressure drop	30 m flc.
Design temperature	300 °C
Temperature difference outlet - inlet	25 K
Heating surface	75,87 m ²
Insulation thickness	150 mm
Recommended pump size @ 15mflc remaining height to provide consumers	65-200
Recommended motor power	30 kW

	LFO firing	Natural Gas firing
Thermal efficiency:	86,41 %	85,51 %
Fuel consumption:	195,15 kg/h	233,89 Nm ³ /h
Furnace pressure drop:	935 Pa	988 Pa
Combustion air consumption:	2603 Nm ³ /h	2518 Nm ³ /h
Exhaust gas outlet volume flow:	2762 Nm ³ /h	2775 Nm ³ /h
Exhaust gas outlet temperature:	313 °C	316 °C
Specific furnace load:	490 kW/m ³	495 kW/m ³