

Heater type: TH - 30

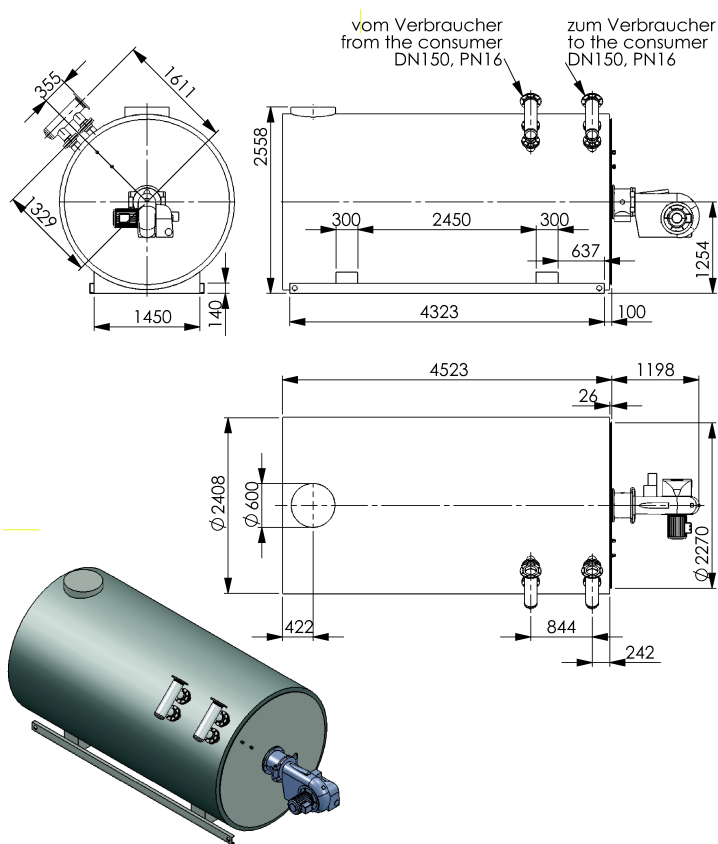

Nominal capacity	3000 kW
Thermal fluid content	2706 l
Weight without filling	7780 kg
Nominal thermal fluid volume flow	211 m ³ /h
Thermal fluid pressure drop	29 m flc.
Design temperature	300 °C
Temperature difference outlet - inlet	25 K
Heating surface	107 m ²
Insulation thickness	150 mm
Recommended pump size @ 15mflc remaining height to provide consumers	100-200
Recommended motor power	37 kW

	LFO firing	Natural Gas firing
Thermal efficiency:	86,02 %	85,06 %
Fuel consumption:	294,05 kg/h	352,69 Nm ³ /h
Furnace pressure drop:	1030 Pa	1090 Pa
Combustion air consumption:	3922 Nm ³ /h	3797 Nm ³ /h
Exhaust gas outlet volume flow:	4162 Nm ³ /h	4184 Nm ³ /h
Exhaust gas outlet temperature:	321 °C	325 °C
Specific furnace load:	508 kW/m ³	513 kW/m ³