

Heater type: TH - 35

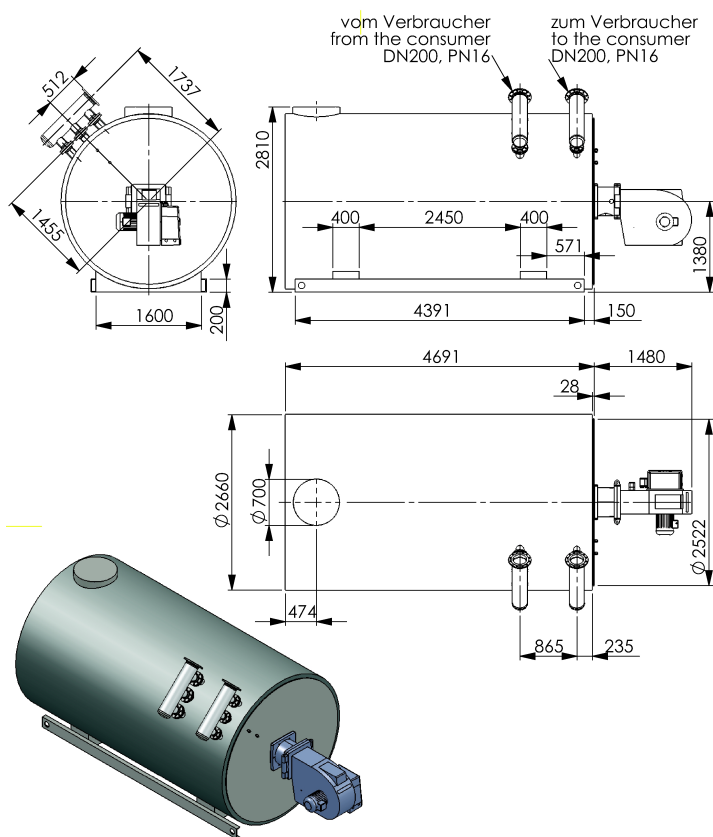

Nominal capacity	3500 kW
Thermal fluid content	2803 l
Weight without filling	9760 kg
Nominal thermal fluid volume flow	246 m ³ /h
Thermal fluid pressure drop	29 m flc.
Design temperature	300 °C
Temperature difference outlet - inlet	25 K
Heating surface	124,11 m ²
Insulation thickness	150 mm
Recommended pump size @ 15mflc remaining height to provide consumers	100-250
Recommended motor power	45 kW

	LFO firing	Natural Gas firing
Thermal efficiency:	86,13 %	85,19 %
Fuel consumption:	342,62 kg/h	410,85 Nm ³ /h
Furnace pressure drop:	1024 Pa	1079 Pa
Combustion air consumption:	4570 Nm ³ /h	4423 Nm ³ /h
Exhaust gas outlet volume flow:	4849 Nm ³ /h	4874 Nm ³ /h
Exhaust gas outlet temperature:	318 °C	322 °C
Specific furnace load:	404 kW/m ³	409 kW/m ³